



Project _____
 AIA # _____ SIS # _____
 Item # _____ Quantity _____ C.S.I. Section 114000

COMPACT SANDWICH PREP TABLES

with Flat Cover/Self-Contained
 UST 32" Wide Models



STANDARD PRODUCT FEATURES

- High Quality Stainless Steel Exterior Top, Sides & Drawers
- Durable, Corrosion Resistant Anodized Aluminum Interior
- Provides NSF7 Performance, Even When Using 6" Deep Pans
- Standard Work Height 34 $\frac{3}{8}$ " on 4" casters
- Environmentally Friendly, Low GWP R-290 Refrigerant
- Top Cut-Outs Accommodate 1/6 Size Pans (divider bars and 4" deep plastic 1/6 size pans provided)
- Reinforced Pan Ledge (holds pans securely level)
- Reversible, Full Length White Nylon Cutting Board
- Stainless Steel Insulated Pan Lid with (2) Open Positions
- Automatic Non-Electric Condensate Evaporator
- Full-Length Drawer Handle with Gasket Guard
- EZ-Clean Drawer Gasket(s)
- Self-Closing Drawers with Stay Open Feature
- Heavy-Gauge Stainless Steel Drawer with Slide
- Electronic Control
- Interior Mounted Thermometer
- 8' Cord & Plug Attached
- Set of (4) 4" Casters



This unit is listed to the applicable ETL and NSF Standards by an approved NRTL. Consult the factory or unit's data plate for approval information.

ACCESSORIES & OPTIONS (*field installed)

- CK20 (four 6" (15.2 cm) high casters for 32" models)
- CK24 (four 3 $\frac{1}{2}$ " (8.9 cm) high casters for 32" models)
- CK26 (four 2 $\frac{3}{4}$ " (6.9 cm) high casters for 32" models)
- CK28 (four 2 $\frac{1}{2}$ " (6.4 cm) high casters for 32" models)
- LK4 (four 6" (15.24 cm) high legs for 32" models)

AVAILABLE CONFIGURATIONS

32" Wide Two Drawer Models

Model	Model Type
UST3212-D	32" Wide, 12 Pans on Top Rail / 8 Pans per Drawer

FACTORY INSTALLED OPTIONS

- Stainless Steel Finished Back (model numbers will have '-SB' suffix)

Approved by _____ Date _____ Approved by _____ Date _____



COMPACT SANDWICH PREP TABLES

with Flat Cover/Self-Contained

UST 32" Wide Models

MODEL:

UST3212-D

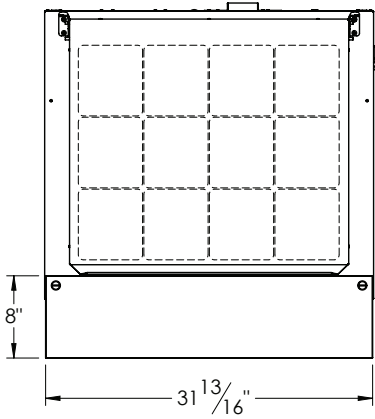

TOP VIEW

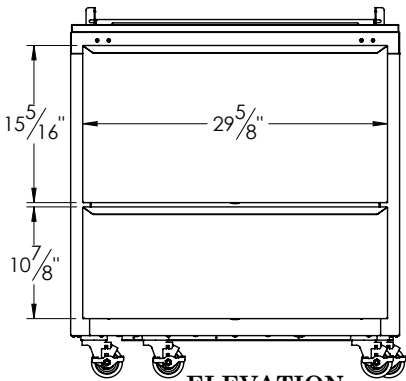

ELEVATION

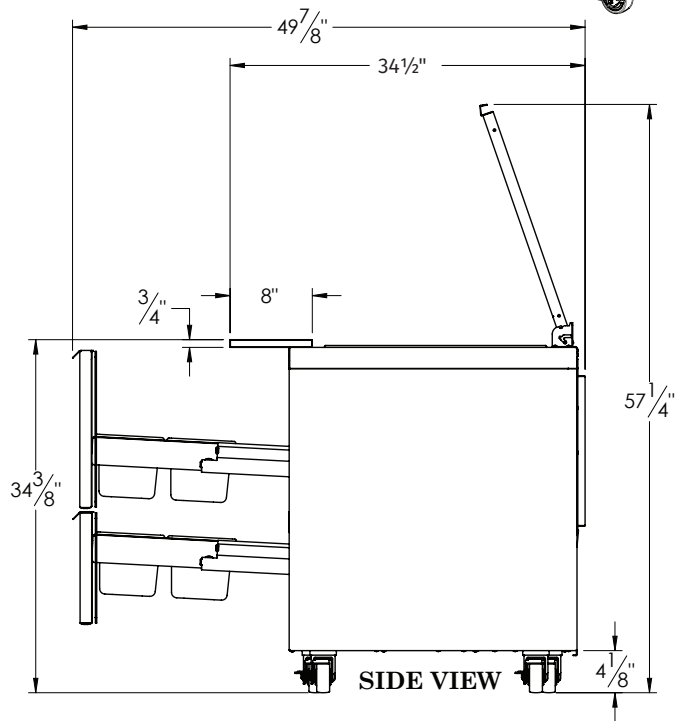
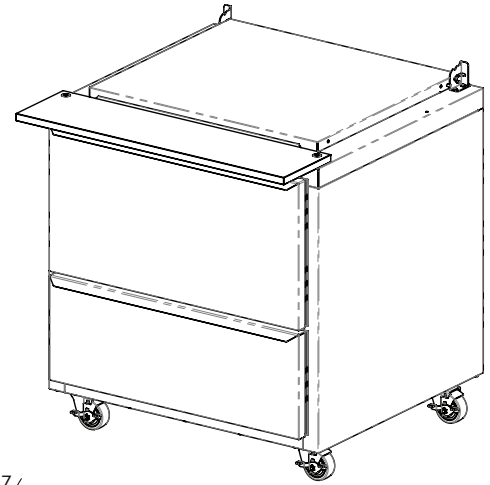

SIDE VIEW

➤ CAD and/or Revit Files Available

<https://traulsen.klclcad.com/>



COMPACT SANDWICH PREP TABLES

with Flat Cover/Self-Contained
UST 32" Wide Models

MODEL

UST3212-D

EQUIPMENT SPECIFICATIONS

MODELS	UST3212
DIMENSIONAL DATA	
Drawers per cabinet	2
# of 1/6 Size Pan Top	12
# of 1/6 Size pans per drawer	8
# of 1/6 Size pans per unit	28
Length - overall in.	31 ¹³ / ₁₆ (80.8 cm)
Depth - overall in. ¹	34 ¹ / ₂ (87.6 cm)
Depth - cutting board in.	8 (20.3 cm)
Width - drawer in.	29 ⁵ / ₈ (75.3 cm)
Height - overall on 4" casters	36 (91.4 cm)
Work Height on 4" casters	34 ³ / ₈ (87.3 cm)
ELECTRICAL DATA (NEMA 5-15P attached)	
Voltage	115/60/1
Full Load Amperes	7.2
REFRIGERATION DATA	
Refrigerant	R-290
Refrigerant Charge oz.	3.5 (99.2 g)
BTU/HR ² HP	1525 ¼ HP
SHIPPING DATA	
Length - crated in.	45 (114.3 cm)
Width - crated in.	42 (106.7 cm)
Height - crated in.	41 (104.1 cm)
Volume - crated cu. ft.	53 (1500.8 l)
Weight - crated lbs.	254 (115.2 kg)

NOTES:

- Overall depth figure includes standard cutting board
- Compressor BTU based on a 90°F ambient and 20°F evaporator

When ordering please specify: Voltage, Hinging, and Options.

Equipped with one NEMA 5-15P Plug 

CONSTRUCTION, HARDWARE, INSULATION

Cabinet exterior front, one piece sides, pan lid, and drawers are constructed of heavy gauge stainless steel. Cabinet interior is constructed of anodized aluminum.

The exterior cabinet back and bottom are constructed of galvanized steel. The cabinet is insulated with an average of 2" thick high density, non-CFC, foamed in place polyurethane.

A ¾" thick, full-length, reversible white nylon cutting board is supplied standard.

PANS & COVER

Each model is supplied standard with its full compliment of 4" deep plastic 1/6 size pans and stainless steel pan dividers. The insulated lift-up pan cover is constructed of stainless steel, and is easily removable for cleaning.

REFRIGERATION SYSTEM

A balanced, rear mounted, front breathing, self-contained refrigeration system using environmentally-friendly, low GWP R290 refrigerant is provided. It features a capillary tube metering device, air-cooled hermetic compressor, a forced air evaporator coil and a non-electric condensate evaporator. An 8' cord and plug is provided. Standard operating temperature of the refrigerated base is 34 to 38°F (1.1° to 3.3°C).

CONTROLLER

An electronic digital control is supplied standard. It includes a 3-Digit LED display, and a Fahrenheit or Celsius temperature scale display capability.

DRAWERS

They are constructed using heavy gauge stainless steel drawer slides and 1-5/16" diameter stainless steel rollers. Gasket profile and material simplify cleaning and increase overall gasket life. Drawers include both a self-closing and stay-open feature.

WARRANTY

Both a six year parts and labor warranty and a seven year compressor parts warranty (self-contained models only) are provided standard.